

AQUASYSTEM®



Organizzazione con Sistema
di Gestione certificato
Company with Management
System certified
ISO 9001:2000

Catalogo Generale
General Catalogue - Catalogue Général

TÜV TÜV Rheinland Group

CERTIFICATE

EC-Type-Examination
acc. to Directive 97/23/EC
Certificate-No.: P 28104081

AQUASYSTEM S.r.l.
Strada Marchesane, 111
36061 Bassano del Grappa (VI)
ITALY

We hereby certify, that the type example mentioned below meets the requirements of the

EC-Type-Examination (Module B)
28104081
Expansion and Surge Tanks
Type: VAV – VAO & VRV (see Annex to Certificate)
(see Annex to Certificate)
AQUASYSTEM S.r.l.

TÜV CERT

CERTIFICATE

Quality-Assurance System
acc. to European Directive 97/23/EC
Certificate-No.: 01 202 I/Q-07 3483

Name and address of manufacturer:
AQUASYSTEM S.r.l.
Via Camazzole, 50/A
I-35010 Carmignano di Brenta (PD), Italy

We hereby certify, that the manufacturer has introduced and implemented a Quality-Assurance-System according to the European Directive 97/23/EC. The manufacturer has the permission to affix the following CE marking to pressure equipment described and manufactured in accordance to the scope covered by this Quality-Assurance System:

CE 0035
QA System (Module H1)
(The QA-System modules E1, E, D1, D and H are covered by module H1)

Approved acc. to Directive 97/23/EC:
Audit Report No.: P28107276
Scope: Design and Manufacture of expansion and surge tanks, see annex
Plant: AQUASYSTEM S.r.l.
Via Camazzole, 50/A
I-35010 Carmignano di Brenta (PD), Italy

The Certificate is valid until
August 31, 2010

Berlin, October 02, 2007

TÜV Rheinland
Industrie Service GmbH
Am Grauen Stein
51105 Cologne, Germany
Tel: ++49-307562-1670
Fax: ++49-307562-1370
e-mail: freitag@de.tuv.com

TÜV CERT-Certification Body
for Pressure Equipment
Dr. Ing. J. Freitag
Notified Body, ID-No. 0035
Member of: CECC

TÜV CERT

CERTIFICATE

L'Organismo di Certificazione TÜV Rheinland Group, the Factory

Aquasystem S.r.l.
Via Camazzole, 50/A
I- 35010 Carmignano di Brenta (PD)

Progettazione e produzione di v.a. ed autoclavi, EA 17

Mediante un audit, rapporto N° 1960509, è stata conseguita la certificazione che le prestazioni della norma UNI EN ISO 9001:2000 sono soddisfatte.

Fare riferimento al Manuale della Qualità per i dettagli sulle esclusioni rispetto ai requisiti della norma. N° di registrazione del certificato: 39 00 1960509

La validità del presente certificato è subordinata a sorveglianza periodica annuale / semestrale ed al riesame completo del sistema di gestione aziendale con periodicità triennale.

Milano, il 20/07/2007. Prima Certificazione: 10/05/2004

SINCERT

L'Organismo di Certificazione TÜV Rheinland Group

TÜV TÜV Rheinland Group



Poland Ukraine Great Britain România Czech Republic Russia France Russia

qualità certificata
certified quality qualité certifiée

Azienda	4
Company profile - Profil de l'usine	

Acqua calda	5	
Hot water - Eau Chaude		
Scelta e dimensionamento dei vasi d'espansione	6-7	
How to choose an expansion tank		
Comme choisir les vases d'expansion		
VR	Vasi espansione a membrana intercambiabile	8-10
VRV	Expansion vessels with interchangeable bladder	
	Vases d'expansion à vessie interchangeable	
VS	Vasi espansione a membrana intercambiabile solari	11
VSV	Expansion vessels with interchangeable bladder for solar system	
	Vases d'expansion gamme solaire	

Acqua fredda	13	
Cold Water - Eau Froide		
Scelta e dimensionamento dei vasi d'espansione	14-15	
How to choose a pressure tank		
Comme choisir les réservoirs		
VA	Autoclavi verticali con membrana intercambiabile	16-18
VAV	Vertical pressure tanks with interchangeable bladder	
	Réservoirs verticaux à vessie interchangeable	
VAO	Autoclavi orizzontali con membrana intercambiabile	19
	Horizontal pressure tanks with interchangeable bladder	
	Réservoirs horizontaux à vessie interchangeable	
VB/VBV	Autoclavi alta pressione con membrana intercambiabile(16 bar)	20-21
	Vertical high pressure tanks with interchangeable bladder	
	Réservoirs verticaux haute pression à vessie interchangeable	
VKV	Autoclavi alta pressione con membrana intercambiabile(25-40bar)	22
	Vertical high pressure tanks with interchangeable bladder	
	Réservoirs verticaux haute pression à vessie interchangeable	
AX/AVX/AHX	Autoclavi inox con membrana intercambiabile	23
	Stainless steel tanks with interchangeable bladder	
	Réservoirs inox à vessie interchangeable	
AZ/AVZ	Autoclavi zincate con membrana intercambiabile	24
	Galvanized tanks with interchangeable bladder	
	Rédervoirs zingués à vessie interchangeable	
AR	Vasi multifunzione con membrana intercambiabile	25
	Multifunction tanks with interchangeable bladder	
	Réservoirs multifonction à vessie interchangeable	

Accessori e ricambi	27-32
Accessories and spare part	
Accessories et pièces de rechange	

Condizioni di vendita	35
Terms of sale - Conditions de vente	

AQUASYSTEM®

Aquasystem è stata una delle prime aziende negli anni sessanta a costruire autoclavi a membrana e vasi di espansione con membrana intercambiabile. Da oltre quarant'anni Aquasystem è impegnata ad offrire il massimo sforzo con l'obiettivo di soddisfare il cliente grazie ad un prodotto di "qualità", sempre con particolare attenzione al rispetto dell'ambiente in cui viviamo.

Negli impianti modernissimi ed altamente automatizzati vengono prodotti ogni giorno migliaia di vasi da 2 a 5000 litri, in centinaia di modelli diversi per le più svariate esigenze della clientela di tutto il mondo; ma tutti controllati minuziosamente nei vari passaggi produttivi.

Aquasystem è certificata dall'ente europeo Tuv iso 900:2001 per la progettazione e la produzione di vasi ed autoclavi.

Tutti i vasi sono marchiati CE in conformità alla direttiva europea 97/23/EC (PED) e hanno ottenuto le più importanti certificazioni mondiali quali ACS,WRAS,GOST. Le strategiche scelte di partnership con i nostri fornitori ci permettono di offrire un prodotto di alta qualità frutto di continue ricerche di materiali e soluzioni tecnologicamente innovative.

Un giovane e affiatato team di collaboratori ogni giorno lavora con passione e professionalità garantendo con la nostra lunga esperienza il miglior servizio al cliente.

In the sixties, Aquasystem has been one of the first companies that started to manufacture expansion vessels and pressure tanks with interchangeable bladder. For more than forty years now, Aquasystem has been devoting itself to meet the clients' needs offering a product of high quality, and, at the same time, always paying attention to our environment.

Thanks to our modern and high-technology facilities, thousands of tanks from 2 up to 5000 litres are produced daily, in hundreds of different models in order to meet all the requirements our clients send us from all over the world. All our tanks are meticulously checked in every phase of the manufacturing process.

Aquasystem is certified by the European body TUV CERT according to the standard ISO 9001:2000 for the production of expansion vessels and pressure tanks.

All our tanks are marked CE according to EU directive 97/23/EC (PED). They obtained the most prestigious international certificates, like ACS,WRAS,GOST.

Our strategic choices of partnership with our suppliers guarantee us the certainty that we offer a high quality product which is the result of our constant search for technologically innovative materials and solutions.

Thanks to our long experience and our young and unified team, which always work with passion and professionalism, Aquasystem provides our clients the best service.

Aquasystem a été une de première entreprise dans les années 60 à construire autoclaves à vessie et vases d'expansion à vessie interchangeable.

Dépuis 40 ans, Aquasystem s'est engagée à offrir le maximum d'effort afin de satisfaire le client grâce à un produit de "qualité", toujours avec une attention particulière au respect du milieu dans lequel nous vivons.

Dans les équipements très modernes et hautement automatisés ils sont produits chaque jour millier de réservoirs à partir de 2lt jusqu'à 5000lt, dans des centaines de modèles différents pour répondre aux exigences les plus diverses de clients de tout le monde; mais nos produits sont tous minutieusement contrôlés pendant les différents processus productifs.

Aquasystem est certifiée de l'organisme TUV ISO 9000:2001 pour le projet et la production des vases d'expansion et autoclaves.

Tous les vases sont marqués CE en conformité aux directives européennes 97/23/EC (PED) et ils ont obtenu les plus importantes certifications mondiales comme ACS, WRAS,GOST.

Les stratégies de partnership choisies avec nos fournisseurs nous donnent l'opportunité d'offrir un produit d'haute qualité, fruit de continuelles recherches de matériaux et solutions avancées.

Un jeune et bien entendu team de collaborateurs travaille chaque jour avec passion et professionnalisme pour garantir, avec notre longue expérience, le meilleur service au client.

acqua calda
hot water - eau chaude



VR (2-50)



VS - VSV (12 ÷ 80)



VRV (35 ÷ 500)



VRV (750 ÷ 3000)

Vaso di espansione per riscaldamento

Expansion tanks

Vases d'expansion a vassie interchangeable

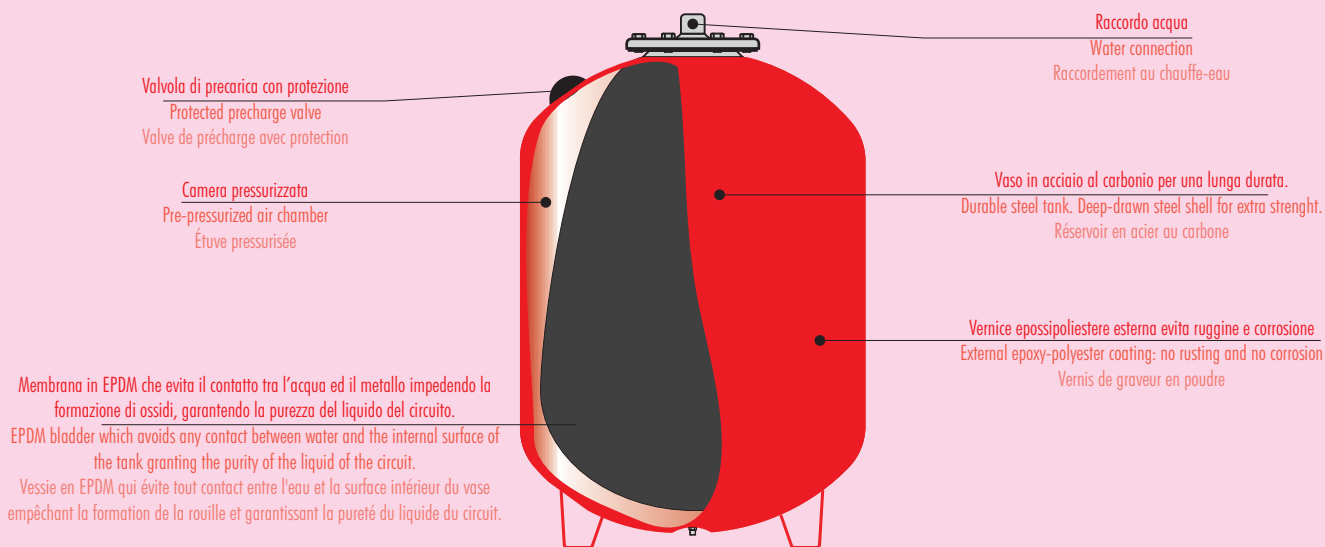

Membrana in EPDM che evita il contatto tra l'acqua ed il metallo impedendo la formazione di ossidi, garantendo la purezza del liquido del circuito.
 EPDM bladder which avoids any contact between water and the internal surface of the tank granting the purity of the liquid of the circuit.
 Vessie en EPDM qui évite tout contact entre l'eau et la surface intérieur du vase empêchant la formation de la rouille et garantissant la pureté du liquide du circuit.

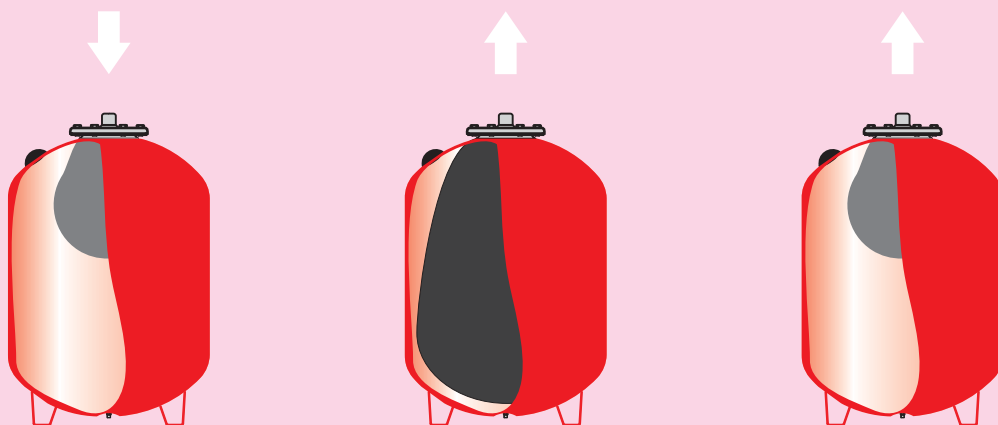

Tutti i vasi della serie VR (VRV, VS e VSV) escono dalla fabbrica controllati, verificati e certificati.
 Una volta connesso al circuito a cui è destinato, all'aumentare della temperatura, aumenta il volume dell'acqua che espandendosi comincia a riempire la membrana.

All the tanks of our VR VRV VS and VSV range are manufactured, tested, checked and certified by our company.
 Once the tank is connected to the system, the temperature increases, and with it also increases the water volume which starts to fill the membrane.

Toute les vases d'expansion de série VR (VRV, VS et VSV) sortent de notre usine contrôlé, vérifié et certifié.
 Lorsque le vase est raccordé à l'installation l'eau va chauffer, son volume augmente et commence ainsi à remplir la vessie.

Il volume dell'acqua continua ad aumentare sino a quando, raggiunta la temperatura massima, la membrana occupa la quasi totalità del volume del vaso. La presenza della membrana evita qualsiasi contatto tra l'acqua e la superficie interna del vaso.

The water volume keeps expanding until the maximum working temperature is reached. At this stage the membrane occupies almost all the space inside the tank. The pressurized air cushion avoids any contact between water and the internal surface of the tank.

Le volume de l'eau continue à augmenter jusqu'à l'eau atteigne sa température maximum et la vessie occupe presque complètement le vase. La vessie évite tout contact entre l'eau et la surface intérieur du vase.

Gradualmente la temperatura dell'impianto inizia a scendere e con essa il volume dell'acqua, il vaso cede ora l'acqua all'impianto grazie alla pressione dell'aria della camera pressurizzata sino al raggiungimento del volume iniziale ed il ciclo si riavvia.

Gradually the temperature goes down and so does the water volume. Because of the pressure of the air cushion the water starts to come out of the tank until the membrane reaches its initial volume. At this point a new cycle begins.

Lorsque la température du système se refroidisse, le volume de l'eau descend et le vase délivre eau à l'installation grâce à la pression de l'air qu'il y a dans l'étuve pressurisée. À la fin, quand le système retourne à sa position initial, un nouveau cycle commence.

Lo scopo principale di utilizzo del vaso di espansione a membrana è la compensazione dell'aumento del volume d'acqua dovuto alla variazione della temperatura negli impianti di riscaldamento.

A titolo esplicativo si può dire che l'acqua, passando da una temperatura di 0°C ad una di 100°C, produce un aumento di volume pari circa al 4,5%: ciò significa che dev'essere presente uno "spazio" interno al circuito in cui l'acqua possa essere contenuta. Tale "spazio" è costituito dal vaso di espansione.

Scelta e dimensionamento

L'aumento del volume d'acqua dell'impianto viene assorbito dal vaso, ciò significa che il volume utile del vaso dev'essere maggiore del volume di espansione dell'impianto. Il volume utile, si ottiene come segue:

Volume utile $\eta = e \times C$

In cui:

e = Coefficiente di espansione dell'acqua; dato dalla differenza tra il coefficiente di dilatazione dell'acqua alla massima temperatura di esercizio ed il coefficiente di dilatazione dell'acqua alla temperatura con impianto spento (generalmente vengono considerate $T_{max} = 90^\circ\text{C}$ e $T_{min} = 10^\circ\text{C}$, per cui $e = 0,0359$; vedere la tabella riportata in calce alla pagina).

C = Capacità complessiva, in litri, dell'impianto (in linea di massima, compreso tra i 10 e i 20 litri ogni 1000 Kcal/h di potenzialità della caldaia)

Per il calcolo esatto del vaso di espansione da installare, utilizzare la seguente formula:

$$V_{\text{vaso}} = \frac{\eta}{1 - \frac{(P_i+1)}{(P_f+1)}}$$

in cui:

η = Volume utile del vaso da installare

P_i = Pressione assoluta di precarica del vaso (in bar)

P_f = Pressione massima assoluta di esercizio a cui è stata tarata la valvola di sicurezza (espressa in bar), tenendo conto del dislivello di quota esistente tra valvola e vaso

Esempio di calcolo

Dati dell'impianto:	per cui si ottiene
$e = 0,0359$	it follows that
$C = 400$ litri	en conséquence on obtient
$P_i = 1,5$ bar	
$P_f = 3$ bar	

$$V_{\text{vaso}} = \frac{0,0359 \times 400}{1 - \frac{(1,5+1)}{(3+1)}} = 38,3 \text{ litri}^*$$

*In ogni caso adotteremo la misura commerciale che più si avvicina, per eccesso, al valore calcolato

The main purpose of an expansion tank is to compensate the variation of the volume of water due to the variation of the temperature in heating systems.

For example, the water heating up from 0°C to 100°C increases its volume of about 4,5%. This means that there should be a space inside the system that can keep the exceeding volume of water. This space is the expansion tank.

How to choose the expansion tank

The increase of water volume is absorbed by the tank. This means that the volume of the tank must be higher than the total possible expansion of the heating system. The volume can be calculated using the following formula:

Useful volume $\eta = e \times C$

e = expansion coefficient of the water; this is the difference between the expansion of the water at its maximum temperature and the expansion of the water at its minimum temperature when the system is not working (usually $T_{max} = 90^\circ\text{C}$ and $T_{min} = 10^\circ$ therefore $e = 0,0359$; see table below)

C = total capacity of the system (usually between 10 and 20 litres for each 1000Kcal/h of boiler power).

To calculate the exact size of the tank to be installed use the following formula:

$$V_{\text{tank}} = \frac{\eta}{1 - \frac{(P_i+1)}{(P_f+1)}}$$

where:

η = internal volume of the tank

P_i = pre-charge pressure of the tank (bar)

P_f = maximum pressure set on the safety valve considering the difference in height between the valve and the tank(bar)

Example

System data:	
$e = 0,0359$	$C = 400$ litri
$P_i = 1,5$ bar	$P_f = 3$ bar

Temperatura dell'acqua (°C)	Coefficiente di dilatazione	Temperatura dell'acqua (°C)	Coefficiente di dilatazione
0	0.00013	65	0.01980
10	0.00025	70	0.02269
20	0.00174	75	0.02580
30	0.00426	80	0.02899
40	0.00782	85	0.03240
50	0.01207	90	0.03590
55	0.01450	95	0.03960
60	0.01704	100	0.04343

*In any case we will adopt the closest measure to the calculated value

Le vase d'expansion sert à compenser l'augment de volume de l'eau dû à la variation de la température dans le système de chauffage.

Uniquement à titre explicatif on peut dire que l'eau augmente son volume de presque 4,5% la température passant de 0°C à 100° : ça signifie qu'il faut avoir un espace à l'intérieur du circuit qui contient l'eau.

Quelle taille le vase d'expansion devrait-il être ?

L'installation amortise l'augmentation de volume de l'eau. Pour cette raison, la taille du vase d'expansion doit être plus grand du volume d'expansion de l'installation.

Le calcul du volume peut être effectué en appliquant la formule suivante :

Volume utile $\eta = e \times C$

Où:

e = coefficient d'expansion de l'eau; il peut être calculé en soustrayant le coefficient d'expansion de l'eau à la température maximum de fonctionnement de l'installation au coefficient d'expansion de l'eau à la température de remplissage (en général $T_{max} = 90^\circ\text{C}$ et $T_{min} = 10^\circ\text{C}$, donc $e = 0,0359$; voir le tableau au bas de la page) ;

C = capacité total de l'installation en litres (en général, entre 10 et 20 litres chaque 1000 Kcal/h de potence de la chaudière).

On peut calculer quelle taille le vase d'expansion devrait être en appliquant le formule suivante :

$$V_{\text{vase}} = \frac{\eta}{1 - \frac{(P_i+1)}{(P_f+1)}}$$

Où:

η = volume utile du vase qu'on veut installer

P_i = pression de tarage (en bar)

P_f = pression maximum de fonctionnement comme la valve à été chargée en considérant la dénivellation entre la valve et le vase d'expansion.

Exemple de calcul :

Données de l'installation :	
$e = 0,0359$	$C = 400$ litri
$P_i = 1,5$ bar	$P_f = 3$ bar

* En tout cas, nous adapterons la taille commercial que plus s'approche, pour excès, à la valeur calculée.

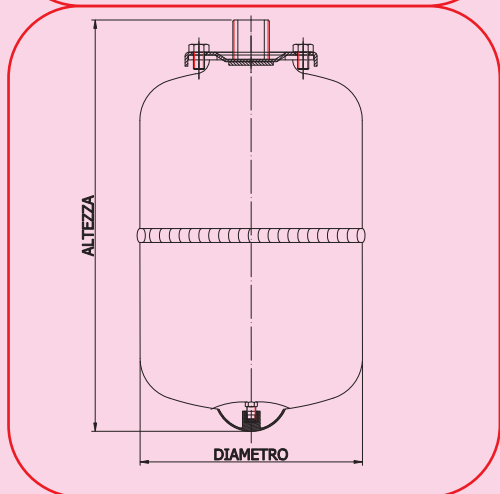

Vasi d'espansione con membrana intercambiabile
Expansion vessels with interchangeable bladder
Vases d'expansion à vessie interchangeable

Marcati CE secondo la Direttiva PED 97/23/CE
 CE marked according to Directive
 Avec le marque CE selon la Directive

Pressione massima d'esercizio Maximun working pressure Pression maximale d'exercice	Pressione di precarica standard Standard pre-loading pressure Pression de precharge standard	Temperatura d'esercizio Working temperature Température d'exercice
5 bar	1,5 bar	-10°C/+100°C
Finitura esterna colore External finish coulor Couleur de finition externe	Membrana in gomma Rubber membrane Vassie en caoutchouc	
Rosso/Red/Rouge RAL 3000	EPDM	

Utilizzo - Use - Utilisation

Circuiti acqua calda, autoclave di pressurizzazione acqua calda
 Hot water circuits, pressurizing surge tanks
 Circuities eau chaude, vase de pressurisation eau chaude

Codice Code Code	Modello Model Modèle	Altezza Height Hauteur (mm)	Diametro Diameter Diamètre (mm)	Imballo Packing Emballage (mm)	Attacco Connection Raccordement
AACRE00R01BE1	VR2	189	160	(Pz12) 329X329X609	3/4"
AADRE00R01BD1	VR5	296	160	(Pz8) 329X329X609	3/4"
AAERE00R01BD1	VR8	310	200	(Pz8) 419X419X638	3/4"
AAFRE00R01BD1	VR12	295	280	(Pz8) 564X564X626	3/4"
AAGRE00R01DC1	VR18	465	280	(Pz4) 551X551X430	3/4"
AAIRE00R01DC1	VR24	492	280	(Pz4) 551X551X488	3/4"
AAJRE00R01DA1	VR35	415	365	(Pz1) 451X366X382	3/4"
AAKRE00R01DA1	VR50	545	365	(Pz1) 565X365X384	3/4"

Vasi d'espansione con membrana intercambiabile
Expansion vessels with interchangeable bladder
Vases d'expansion à vessie interchangeable

Marchi CE secondo la Direttiva PED 97/23/CE
CE marked according to Directive
Avec le marque CE selon la Directive

Pressione massima d'esercizio Maximun working pressure Pression maximale d'exercice	Pressione di precarica standard Standard pre-loading pressure Pression de precharge standard	Temperatura d'esercizio Working temperature Température d'exercice
5 bar	1,5 bar	-10°C/+100°C
Finitura esterna colore External finish color Couleur de finition externe	Membrana in gomma Rubber membrane Vassie en caoutchouc	
Rosso/Red/Rouge RAL 3000	EPDM	

Utilizzo - Use - Utilisation

Circuiti acqua calda, autoclave di pressurizzazione acqua calda
 Hot water circuits, pressurizing surge tanks
 Circuits eau chaude, vase de pressurisation eau chaude

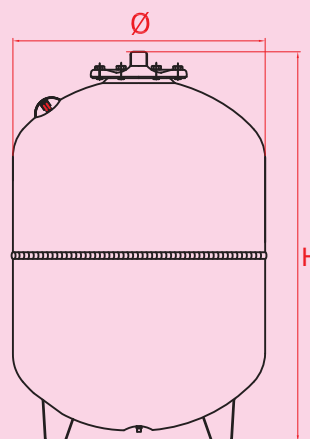

Codice Code Code	Modello Model Modèle	Altezza Height Hauteur (mm)	Diametro Diameter Diamètre (mm)	Imballo Packing Emballage (mm)	Attacco Connection Raccordement
AAJRE01R01DA1	VRV35	450	365	(Pz1) 451X366X382	3/4"
AAKRE01R01DA1	VRV50	564	365	(Pz1) 565X365X384	3/4"
AALRE01R01DA1	VRV60	668	365	(Pz1) 695X369X378	3/4"
AAMRE01R01EA1	VRV80	687	410	(Pz1) 691X416X432	1"
AANRE01R01EA1	VRV100	663	495	(Pz1) 690X495X517	1"
AAORE01R01EA1	VRV120	733	495	(Pz1) 806X501X502	1"
AAPRE01R01EA1	VRV150	795	550	(Pz1) 835X555X590	1"
AAQRE01R11EA1	VRV200	1020	600	(Pz1) 1020X600X597	1"
AARRE01R21EA1	VRV250	986	650	(Pz1) 1270X650X650	1"
AASRE01R11EA1	VRV300	1168	650	(Pz1) 1270X650X650	1"
AATRE01R21FA1	VRV400	1093	750	(Pz1) 1500X732X745	1 1/4"
AAURE01R21FA1	VRV500	1347	750	(Pz1) 1500X732X745	1 1/4"
AAVRE01R11FA1	VRV600	1470	750	(Pz1) 800X800X1610	1 1/4"

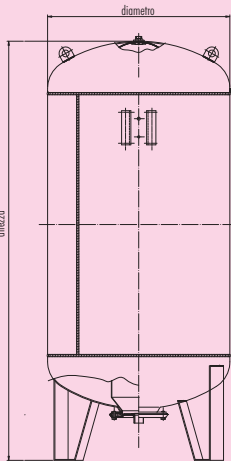

Vasi d'espansione con membrana intercambiabile
Expansion vessels with interchangeable bladder
Vases d'expansion à vessie interchangeable

Marcati CE secondo la Direttiva PED 97/23/CE
 CE marked according to Directive
 Avec le marque CE selon la Directive

Pressione massima d'esercizio Maximum working pressure Pression maximale d'exercice	Pressione di precarica standard Standard pre-loading pressure Pression de precharge standard	Temperatura d'esercizio Working temperature Température d'exercice
10 bar	4 bar	VRV200~VRV1500 -10°C/+100°C VRV2000~VRV5000 -10°C/+70°C
Finitura esterna colore External finish colour Couleur de finition externe		Membrana in gomma Rubber membrane Vessie en caoutchouc
Rosso/Red/Rouge RAL 3000		EPDM VRV500~1500 BUTYL VRV2000~5000

Utilizzo - Use - Utilisation

Circuiti acqua calda, autoclave di pressurizzazione acqua calda
 Hot water circuits, pressurizing surge tanks
 Circuits eau chaude, vase de pressurisation eau chaude

Codice Code Code	Modello Model Modèle	Altezza Height Hauteur (mm)	Diametro Diameter Diamètre (mm)	Imballo Packing Emballage (mm)	Attacco Connection Raccordement
AAXRG01R31GP1	VRV750	1820	800	(Pz1) 800X800X1920	2"
AAYRG01R31HP1	VRV1000	2250	800	(Pz1) 800X800X2400	2"
AAZRG01R31HP1	VRV1500	2400	960	(Pz1) 960X2400X1110	2"
AAARG01R31NP1	VRV2000	2500	1100	(Pz1) 1100X2500X1250	2"
AABRG01R31OP1	VRV3000	2750	1200	(Pz1) 1200X2750X1350	Dn65
AA4RG02R31OP1	VRV4000	3220	1450	(Pz1)1450X2750X1600	Dn80
AA5RG02R31OP1	VRV5000	3620	1450	(Pz1) 1500X3250X1650	Dn80



Vasi d'espansione per impianti solari
Expansion vessels for solar system
Vases d'expansion gamme solaire

Marchi CE secondo la Direttiva **PED 97/23/CE**
CE marked according to Directive
Avec le marque CE selon la Directive

Pressione massima d'esercizio Maximun working pressure Pression maximale d'exercice	Pressione di precarica standard Standard pre-loading pressure Pression de precharge standard	Temperatura d'esercizio Working temperature Température d'exercice
5 bar	2,5 bar	-10°C/+100°C
Finitura esterna colore External finish coulor Couleur de finition externe	Membrana in gomma Rubber membrane Vassie en caoutchouc	
Bianco/White/Blanc RAL 9010	EPDM	

Utilizzo - Use - Utilisation

Circuiti acqua calda per sistemi solari,
autoclave di pressurizzazione di acqua calda per impianti solari
Solar system hot water circuits, solar system pressurizing surge tanks
Circuites eau chaude gamme solaire,
vase de pressurisation eau chaude gamme solaire

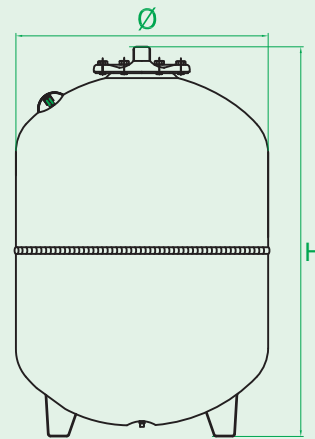

Codice Code Code	Modello Model Modèle	Altezza Height Hauteur (mm)	Diametro Diameter Diamètre (mm)	Imballo Packing Emballage (mm)	Attacco Connection Raccordement
AAFPLOOW01BD1	VS12	295	280	(Pz8) 564X564X626	3/4"
AAGPLOOW01DC1	VS18	465	280	(Pz4) 551X551X430	3/4"
AAIPLOOW01DC1	VS24	492	280	(Pz4) 551X551X488	3/4"
AAJPL01W01DA1	VSV35	450	365	(Pz1) 451X366X382	3/4"
AAKPL01W01DA1	VSV50	564	365	(Pz1) 565X365X384	3/4"
AAMPL01W01EA1	VSV80	687	410	(Pz1) 691X416X432	1"

Modello Model Modèle	N° x scatola x box x boîte	Dimensioni pallet Dimension pallet Dimensions palette P x L x H _i	N° totale total total
VR2	12	1200X800X2000	216
VR5	8	1200X800X2000	144
VR8	8	1300X900X2100	144
VR12	8	1200X1200X2100	96
VR18	4	1200X1150X2200	64
VR24	4	1200X1150X2200	64
VR35	1	940X1200X2100	30
VR50	1	1200X1200X2100	30
VRV35	1	940X1200X2100	30
VRV50	1	1200X1200X2100	30
VRV60	1	1200X1200X2150	20
VRV80	1	1200X1200X2400	20
VRV100	1	1200X1200X2250	16
VRV120	1	1350X1350X2200	16
VRV150	1	840X1200X2000	6
VRV200	1	1230X1030X1950	6

Modello Model Modèle	N° x scatola x box x boîte	Dimensioni pallet Dimension pallet Dimensions palette P x L x H _i	N° totale total total
VRV250	1	1330X1280X2160	6
VRV300	1	1330X1280X2160	6
VRV400	1	1500X1500X2450	6
VRV500	1	1500X1500X2450	6
VRV600	1	800X800X1610	1
VRV750	1	800X800X1920	1
VRV1000	1	800X800X2400	1
VRV1500	1	960X2400X1110	1
VRV2000	1	1100X2500X1250	1
VRV3000	1	1200X2750X1350	1
VRV4000	1	1450X2950X1600	1
VRV5000	1	1500X3250X1650	1
VS12	8	1200X1200X2100	96
VS18	4	1200X1200X2200	64
VS24	4	1200X1200X2200	64
VSV35	1	940x1200x2100	30
VSV50	1	1200x1200x2100	30
VSV80	1	1200x1200x2400	20

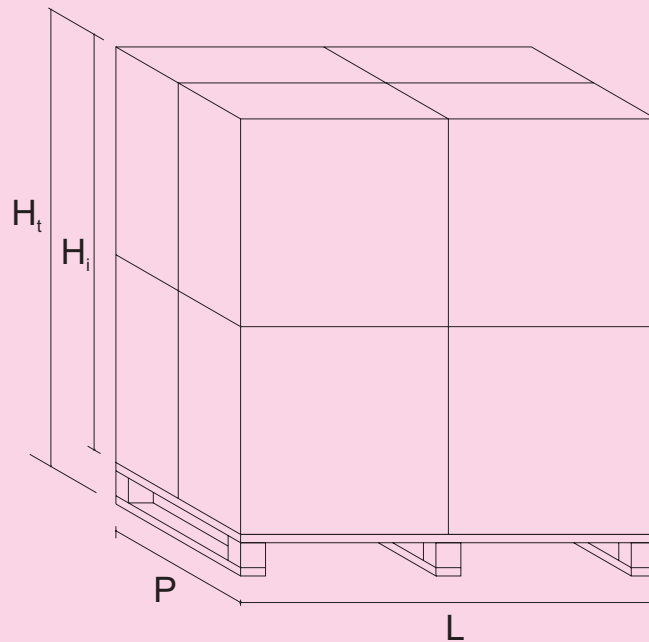

acqua fredda
cold water - eau froide



VAS-VA-VAV



AX-AVX-AHX



AVZ-AZ



VAO



AR



VAV -VBV

Vaso autoclave - Pressure tank -Reservoir à vessie

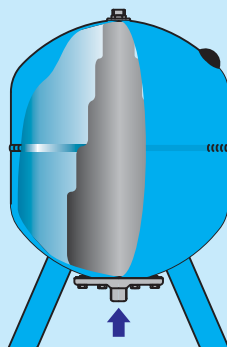
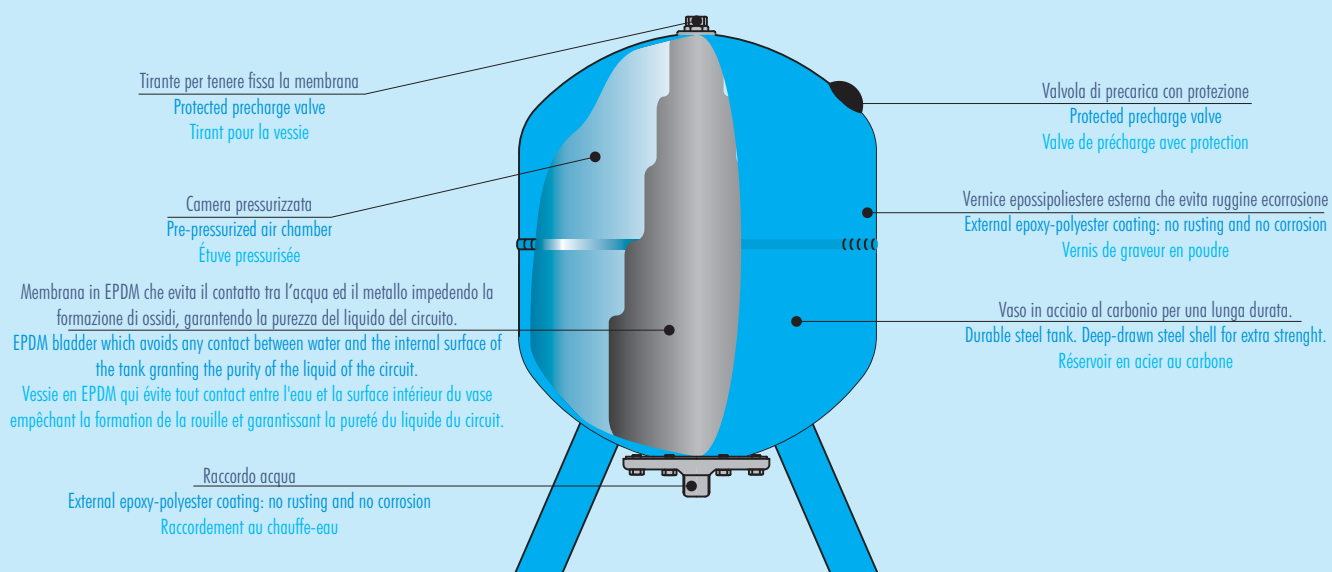

Tutti i vasi "acqua fredda" escono dalla fabbrica controllati, verificati e certificati. La membrana intercambiabile evita qualunque contatto tra aria ed acqua impedendo ogni possibile perdita di pressione, contaminazione e corrosione. Una volta connesso al circuito a cui è destinato, la pompa parte facendo aumentare la pressione dell'impianto, facendo entrare l'acqua nella membrana.

All our tanks for cold water are manufactured, tested, checked and certified by our company.

The interchangeable membrane keeps water and air separated and avoids any contamination, corrosion and pressure loss. Once connected to the water system, the pump starts to raise the pressure letting the water filling in the bladder.

Toutes les réservoirs à vessie sortent de notre usine contrôlé, vérifié et certifié. La vessie interchangeable évite tout contact entre l'eau et la surface intérieure du vase empêchant toutes pertes de pression et tout contamination et corrosion. Dès qu'il est joint au circuit dont il est destiné, la pompe se met en marche, en augmentant la pression de l'installation et en introduisant de l'eau dans la vessie.

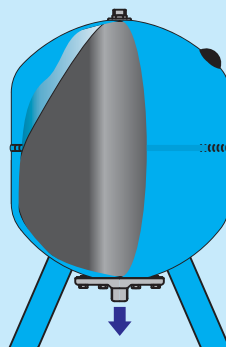

Quando la pressione dell'impianto raggiunge il valore di soglia massima impostata la pompa si arresta. Nel vaso vi è la quantità massima d'acqua accumulabile. Naturalmente la membrana si è dilatata ed occupa la quasi totalità del volume interno del vaso. Se richiamata dall'impianto l'acqua comincia ad uscire senza l'ausilio della pompa sfruttando la pressione dell'aria della camera pressurizzata.

When the pressure reaches its maximum threshold value, the pump stops. Inside the tank there is the greatest quantity of water possible. Obviously the membrane is dilated and it occupies almost all the volume of the tank. If water is required by the system, it starts flowing out of the tank without using the pump but just exploiting the pressure of the air cushion.

Quand la pression de l'installation atteint le niveau maximum de tarage la pompe s'arrête. Le réservoir à vessie contient la quantité maxime d'eau accumulable. Naturellement la vessie est dilatée et occupe presque tout le volume interne du réservoir. Si l'installation le demande, l'eau commence à sortir de l'installation sans l'utilisation de la pompe exploitant la pression de l'aire qu'il y a dans l'étve pressurisé.

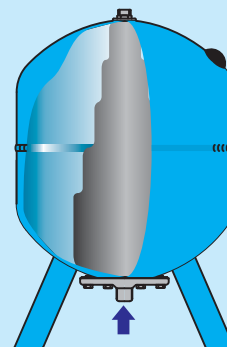

Si prosegue con l'erogazione di acqua all'impianto, la membrana si sgonfia, sino al raggiungimento della pressione di soglia minima dell'impianto. A questo punto, la membrana è ritornata alle dimensioni iniziali, la pompa si riavvia ed il ciclo si ripete. Poiché la gamma "acqua fredda" garantiscono in ogni istante la massima quantità di acqua possibile, le partenze della pompa sono ridotte al minimo.

The process goes on and the membrane deflates until the pressure reaches its minimal threshold value. At this stage the membrane is back to its initial dimensions, the pump starts again and a new cycle begins. Since the tank always grants the maximum water flow, pump insertions are reduced to the minimum.

L'eau continue à augmenter, la vessie se dégonfle jusqu'à on arrive au niveau minimum de pression de l'installation. En ce moment la vessie est retourné à sa dimension initial, la pompe se met en marche de nouveau et le cycle reprend. Puisque la gamme de réservoirs garantit en chaque moment la maximum quantité d'eau possible, la mis en marche au moyen de la pompe se réduit au minimum possible.

Lo scopo principale di utilizzo del vaso autoclave è di fornire acqua ad una pressione prescelta, indipendentemente dalla pressione di alimentazione, limitando il numero di inserzioni della pompa. L'agente motore che rende possibile questo è costituito da una riserva d'aria (o azoto) sotto pressione immagazzinata tra la membrana e la parete metallica del vaso. Tale cuscino si comprime all'aumentare della pressione, lasciando entrare nel serbatoio l'acqua e quindi immagazzinandola in pressione.

Scelta e dimensionamento

Per il dimensionamento del vaso autoclave utilizzare la seguente formula:

$$V_{\text{vaso}} = K \times A_{\text{max}} \times \frac{(P_{\text{max}} + 1) \times (P_{\text{min}} + 1)}{(P_{\text{max}} - P_{\text{min}}) \times (P_{\text{prec}} + 1)}$$

In cui dovremo tener conto:

- K=Coefficiente in funzione della pompa (vedi tabella)
- A_{max}=Portata media della pompa (espressa in litri/minuto)
- P_{max}=Pressione massima di taratura della pompa (bar)
- P_{min}=Pressione minima di taratura della pompa (bar)
- P_{prec}=Pressione di precarica del vaso (bar)

Attenzione!: Si ricorda di regolare la precarica del vaso 0.2 bar in meno rispetto alla pressione di potenza della pompa

Esempio di calcolo

Con un impianto di caratteristiche:

- Potenza pompa 4 HP
- K= 0,375
- A_{max}= 120 litri/minuto
- P_{max}= 7 bar
- P_{min}= 2,2 bar
- P_{prec}= 2 bar

The main purpose of the pressure tank is to give water at a predefined pressure, regardless of boost pressure, in order to limit the pump insertions. This is due to the pressurised air that is between the membrane and the internal surface of the tank. When the pressure increases, the air cushion compresses letting the water filling in the tank. The water is kept inside the water tank under pressure.

How to choose the tank

The sizing of the tank can be calculated using the following formula:

Where:

- K=working coefficient of the pump (see table)
- A_{max}=average flow (litres/minute)
- P_{max}=maximum working pressure of the pump (bar)
- P_{min}=minimum working pressure of the pump (bar)
- P_{prec}=pre-charge pressure of the tank (bar)

Warning! : Always set the pre-charge of the tank 0,2BAR less than the pump power pressure

Example

System data:

- Pump power 4 HP
- K= 0,375
- A_{max}= 120 litri/minuto
- P_{max}= 7 bar
- P_{min}= 2,2 bar
- P_{prec}= 2 bar

$$V_{\text{vaso}} = 0,375 \times 120 \times \frac{(7+1) \times (2,2+1)}{(7-2,2) \times (2+1)} = 80 \text{ litri}^*$$

* In ogni caso, adottare la misura che più si avvicina, per eccesso, al valore calcolato

* In any case we will adopt the closest measure to the calculated value

Potenza della pompa Pump Power Potence de la pompe (HP)	Coefficiente Coefficient Coefficient (K)
1-2	0,25
2,5-4	0,375
5-8	0,625
9-12	0,875

La fonction principal du réservoir à vessie est de fournir de l'eau à la pression désiré, indépendamment de la pression d'alimentation, en limitant le numéro de connexions de la pompe. La réserve d'air (ou azote) sous pression qu'il y a entre la vessie et la surface intérieur du réservoir fait ça possible. La pression d'air augmentant, ce coussin d'air se comprime et il laisse entrer l'eau qu'il accumulera sous pression.

Quelle taille le réservoir devrait-il être ?

Le calcul pour savoir quelle taille le réservoir devrait être peut être effectué en appliquant la formule suivante :

Où :

- K=Coefficient de fonctionnement de la pompe (voir table ci-dessous)
- A_{max}=Capacité moyenne de la pompe
- P_{max}=Pression maximale de tarage de la pompe(bar)
- P_{min}=Pression minimale de tarage de la pompe (bar)
- P_{prec}=Pression de précharge du reservoir (bar)

Attention! Réglez la pression de précharge du réservoir 0.2 bar moins de la pression de puissance de la pompe.

Exemple de calcul :

Données de l'installation :

- Potence de la pompe 4 HP
- K= 0,375
- A_{max}= 120 litri/minuto
- P_{max}= 7 bar
- P_{min}= 2,2 bar
- P_{prec}= 2 bar

* En tout cas, nous adapterons la taille commercial que plus s'approche, pour excès, à la valeur calculée.



Autoclavi verticali con membrana intercambiabile
Vertical pressure tanks with interchangeable bladder
Réservoirs verticaux à vessie interchangeable

Marcati CE secondo la Direttiva **PED 97/23/CE**
CE marked according to Directive
Avec le marque CE selon la Directive

Pressione massima d'esercizio Maximun working pressure Pression maximale d'exercice	Pressione di precarica standard Standard pre-loading pressure Pression de precharge standard	Temperatura d'esercizio Working temperature Température d'exercice
10 bar (8bar 18-24)	1,5 bar	-10°C/+100°C
Finitura esterna colore External finish coulor Couleur de finition externe	Membrana in gomma Rubber membrane Vassie en caoutchouc	
Blu/Blue/Bleu RAL 5015	EPDM	

Utilizzo - Use - Utilisation

Circuiti acqua calda, autoclave di pressurizzazione acqua calda
Hot water circuits, pressurizing surge tanks
Circuites eau chaude, réservoir de pressurisation eau chaude

Codice Code Code	Modello Model Modèle	Altezza Height Hauteur (mm)	Diametro Diameter Diamètre (mm)	Imballo Packing Emballage (mm)	Attacco Connection Raccordement
AACVE00B01BE1	VA2	189	160	(Pz12) 329X329X609	3/4"
AADVE00B01BD1	VA5	304	160	(Pz8) 329X329X609	3/4"
AAEVE00B01BD1	VA8	316	200	(Pz8) 419X419X638	3/4"
AAFVE00B01BD1	VA12	295	280	(Pz8) 564X564X626	3/4"
AAGVE00B01DC1	VA18	428	280	(Pz4) 551X551X430	3/4"
AAIVE00B01EC1	VA24	489	280	(Pz4) 551X551X488	1"
AAJVE00B01EA1	VA35	450	365	(Pz1) 451X366X382	1"
AAISE00B01EBO	VAS24	335	350	(Pz2) 697X352X335	1"

Autoclavi verticali con membrana intercambiabile
Vertical pressure tanks with interchangeable bladder
Réservoirs verticaux à vessie interchangeable

Marchi CE secondo la Direttiva **PED 97/23/CE**
 CE marked according to Directive
 Avec le marque CE selon la Directive

Pressione massima d'esercizio Maximun working pressure Pression maximale d'exercice	Pressione di precarica standard Standard pre-loading pressure Pression de precharge standard	Temperatura d'esercizio Working temperature Température d'exercice
10 bar	1,5 bar mod. 50-150 2 bar mod.200-500	-10°C/+100°C
Finitura esterna colore External finish coulor Couleur de finition externe	Membrana in gomma Rubber membrane Vassie en caoutchouc	
Blu/Blue/Bleu RAL 5015	EPDM	

Utilizzo - Use - Utilisation

Circuiti acqua calda, autoclave di pressurizzazione acqua calda
 Hot water circuits, pressurizing surge tanks
 Circuits eau chaude, réservoir de pressurisation eau chaude

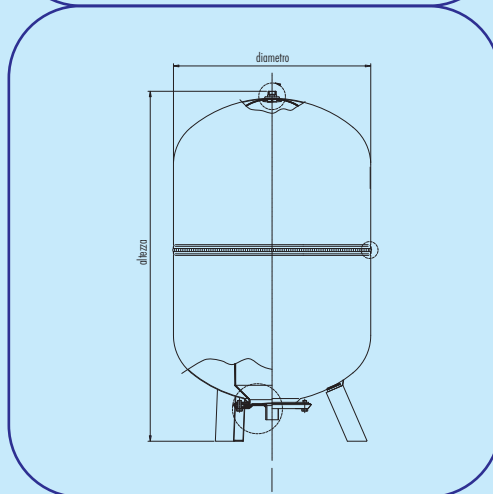

Codice Code Code	Modello Model Modèle	Altezza Height Hauteur (mm)	Diametro Diameter Diamètre (mm)	Imballo Packing Emballage (mm)	Attacco Connection Raccordement
AAKVE01B01EA1	VAV50	656	365	(Pz1) 695X360X365	1"
AALVE01B01EA1	VAV60	761	365	(Pz1) 809X369X358	1"
AAMVE01B01EA1	VAV80	790	410	(Pz1) 814X404X408	1"
AANVE01B11EA1	VAV100	774	495	(Pz1) 806X501X502	1"
AAPVE01B11EA1	VAV150	927	550	(Pz1) 930X550X550	1"
AAQVG01B11FA1	VAV200	1020	600	(Pz1) 1020X600X597	1 ¼"
AASVG02B11FA1	VAV300	1243	650	(Pz1) 1270X650X650	1 ¼"
AAUVG02B11FA1	VAV500	1493	750	(Pz1) 1487X732X745	1 ¼"

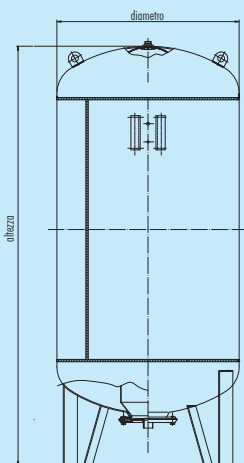

Autoclavi verticali con membrana intercambiabile
Vertical pressure tanks with interchangeable bladder
Réservoirs verticaux à vassie interchangeable

Marchi CE secondo la Direttiva **PED 97/23/CE**
 CE marked according to Directive
 Avec le marque CE selon la Directive

Pressione massima d'esercizio Maximun working pressure Pression maximale d'exercice	Pressione di precarica standard Standard pre-loading pressure Pression de precharge standard	Temperatura d'esercizio Working temperature Température d'exercice
10 bar	4 bar	VAV200~VAV1500 -10°C/+100°C VAV2000~VAV5000 -10°C/+70°C
Finitura esterna colore External finish coulor Couleur de finition externe	Membrana in gomma Rubber membrane Vassie en caoutchouc	
Rosso/Red/Rouge RAL 3000	EPDM VAV500~1500 BUTYL VAV2000~5000	

Utilizzo - Use - Utilisation

Circuiti acqua calda, autoclave di pressurizzazione acqua calda
 Hot water circuits, pressurizing surge tanks
 Circuits eau chaude, réservoir de pressurisation eau chaude

Codice Code Code	Modello Model Modèle	Altezza Height Hauteur (mm)	Diametro Diameter Diamètre (mm)	Imballo Packing Emballage (mm)	Attacco Connection Raccordement
AAXVG01R31GP1	VAV750	1820	800	(Pz1) 800X800X1920	2"
AAVVG01R31HP1	VAV1000	2250	800	(Pz1) 800X800X2400	2"
AAZVG01R31HP1	VAV1500	2400	960	(Pz1) 960X2400X1110	2"
AAAVG01R31NP1	VAV2000	2500	1100	(Pz1) 1100X2500X1250	2"
AABVG01R31OP1	VAV3000	2750	1200	(Pz1) 1200X2750X1350	Dn65
AA4VG02R31OP1	VAV4000	3220	1450	(Pz1)1450X2950X1600	Dn80
AA5VG02R31OP1	VAV5000	3620	1450	(Pz1) 1500X3250X1650	Dn80

Autoclavi orizzontali con membrana intercambiabile
Horizontal pressure tank with interchangeable bladder
Réserveirs horisontaux à vassie interchangeable

Marchi CE secondo la Direttiva **PED 97/23/CE**
 CE marked according to Directive
 Avec le marque CE selon la Directive

Pressione massima d'esercizio Maximun working pressure Pression maximale d'exercice	Pressione di precarica standard Standard pre-loading pressure Pression de precharge standard	Temperatura d'esercizio Working temperature Température d'exercice
10 bar	1,5 bar mod. 18-150 2 bar mod.150-500	-10°C/+100°C
Finitura esterna colore External finish coulor Couleur de finition externe	Membrana in gomma Rubber membrane Vassie en caoutchouc	
Blu/Blue/Bleu RAL 5015	EPDM	

Utilizzo - Use - Utilisation

Circuiti acqua calda, autoclave di pressurizzazione acqua calda
 Hot water circuits, pressurizing surge tanks
 Circuits eau chaude, réservoir de pressurisation eau chaude

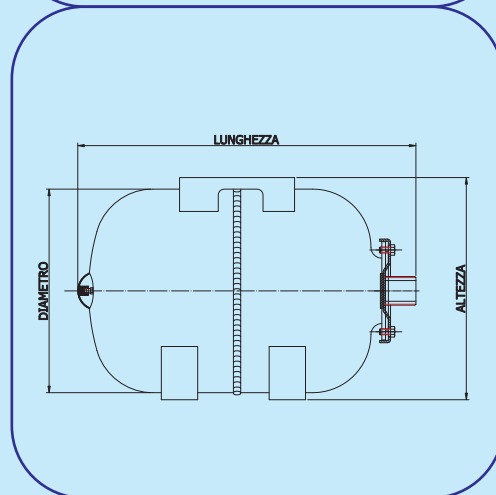

Codice Code Code	Modello Model Modèle	Altezza Height Hauteur (mm)	Lunghezza Length Longueur (mm)	Diametro Diameter Diamètre (mm)	Imballo Packing Emballage (mm)	Attacco Connection Raccordement
------------------------	----------------------------	--------------------------------------	---	--	---	---------------------------------------

AAGOE11B01EC1	VA018	305	465	280	(Pz 4) 600X565X495	1"
AAIOE11B01EC1	VA024	300	492	280	(Pz 4) 600X565X495	1"
AAJOE11B01EA1	VA035	376	450	365	(Pz 1) 451X366X382	1"
AAKOE11B01EA1	VA050	380	570	365	(Pz 1) 565X365X384	1"
AALOE11B01EA1	VA060	385	675	365	(Pz 1) 695X369X378	1"
AAMOE11B01EA1	VA080	430	677	410	(Pz 1) 691X416X432	1"
AANOE11B11EA1	VA0100	520	685	495	(Pz 1) 690X495X517	1"
AAPOE11B11EA1	VA0150	578	820	550	(Pz 1) 835X555X590	1"
AAQOG21B11FA1	VA0200	628	915	600	(Pz 1) 915X600X615	1 ¼"
AASOG21B11FA1	VA0300	680	1082	650	(Pz 1) 1270X650X650	1 ¼"

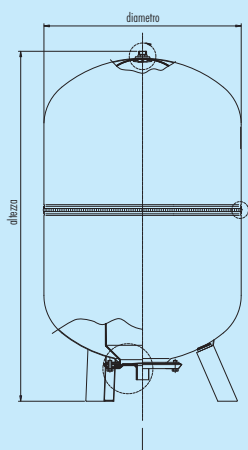
VB**VBV**

Autoclavi per circuiti ad alta pressione
Vertical high pressure tanks
Réservoirs à vassie haute pression

Marchi CE secondo la Direttiva **PED 97/23/CE**
 CE marked according to Directive
 Avec le marque CE selon la Directive

Pressione massima d'esercizio Maximun working pressure Pression maximale d'exercice	Pressione di precarica standard Standard pre-loading pressure Pression de precharge standard	Temperatura d'esercizio Working temperature Température d'exercice
16 bar	2 bar	-10°C/+100°C
Finitura esterna colore External finish coulor Couleur de finition externe		Membrana in gomma Rubber membrane Vassie en caoutchouc
Blu/Blue/Bleu RAL 5015		EPDM

Utilizzo - Use - Utilisation

Circuiti acqua calda, autoclave di pressurizzazione acqua calda
 Hot water circuits, pressurizing surge tanks
 Circuities eau chaude, réservoir de pressurisation eau chaude

Codice Code Code	Modello Model Modèle	Altezza Height Hauteur (mm)	Diametro Diameter Diamètre (mm)	Imballo Packing Emballage (mm)	Attacco Connection Raccordement
AAEBG00B01DD1	VB8	316	200	(Pz8) 419X419X638	3/4"
AAFBG00B01DD1	VB12	295	280	(Pz8) 564X564X626	3/4"
AAGBG00B01DC1	VB18	428	280	(Pz4) 551X551X488	3/4"
AAIBG00B01EC1	VB24	489	280	(Pz4) 551X551X488	1"
AAJBG00B01EA1	VB35	450	365	(Pz1) 451X366X382	1"
AAKBG01B01EA1	VBV50	656	365	(Pz1) 695X360X365	1"
AALBG01B01EA1	VBV60	761	365	(Pz1) 809X369X358	1"
AAMBG01B01EA1	VBV80	790	410	(Pz1) 814X404X408	1"
AANBG01B11EA1	VBV100	774	495	(Pz1) 806X501X502	1"
AAPBG01B11EA1	VBV150	927	550	(Pz1) 930X550X550	1"

Autoclavi per circuiti ad alta pressione
Vertical high pressure tanks
Réservoirs à vassie haute pression

Marchi CE secondo la Direttiva **PED 97/23/CE**
 CE marked according to Directive
 Avec le marque CE selon la Directive

Pressione massima d'esercizio Maximum working pressure Pression maximale d'exercice	Pressione di precarica standard Standard pre-loading pressure Pression de precharge standard	Temperatura d'esercizio Working temperature Température d'exercice
16 bar	2 bar (200-500) 4 bar (750-5000)	VBV200~VBV1500 -10°C/+100°C VBV2000~VBV5000 -10°C/+70°C
Finitura esterna colore External finish color Couleur de finition externe	Membrana in gomma Rubber membrane Vassie en caoutchouc	
Blu/Blue/Bleu RAL 5015	EPDM VBV500~1500 BUTYL VBV2000~5000	

Utilizzo - Use - Utilisation

Circuiti acqua calda, autoclave di pressurizzazione acqua calda
 Hot water circuits, pressurizing surge tanks
 Circuits eau chaude, réservoir de pressurisation eau chaude

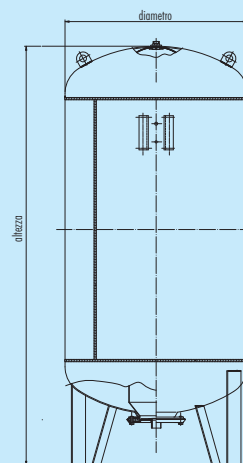

Codice Code Code	Modello Model Modèle	Altezza Height Hauteur (mm)	Diametro Diameter Diamètre (mm)	Imballo Packing Emballage (mm)	Attacco Connection Raccordement
AAQBG01B11FA1	VBV200	1020	600	(Pz1) 1020X600X597	1¼"
AASBG02B11FA1	VBV300	1243	650	(Pz1) 1270X650X650	1¼"
AAUBG02B11FA1	VBV500	1493	750	(Pz1) 1487X732X745	1¼"
AAXBG01R31GP1	VBV750	1820	800	(Pz1) 800X800X1920	2"
AAYBG01R31HP1	VBV1000	2250	800	(Pz1) 800X800X2400	2"
AAZBG01R31HP1	VBV1500	2400	960	(Pz1) 960X2400X1110	2"
AAABG01R31NP1	VBV2000	2500	1100	(Pz1) 1100X2500X1250	2"
AABBG01R31OP1	VBV3000	2750	1200	(Pz1) 1200X2750X1350	DN 65
AA4BG02R31OP1	VBV4000	3220	1450	(Pz1) 1450X2750X1600	DN 80
AA5BG02R31OP1	VBV5000	3620	1450	(Pz1) 1500X3250X1700	DN 80

Autoclavi per circuiti ad alta pressione
Vertical high pressure tanks
Réservoirs haute pression à vassie

Marcati CE secondo la Direttiva **PED 97/23/CE**
 CE marked according to Directive
 Avec le marque CE selon la Directive

Pressione massima d'esercizio Maximum working pressure Pression maximale d'exercice	Pressione di precarica standard Standard pre-loading pressure Pression de precharge standard	Temperatura d'esercizio Working temperature Température d'exercice
25 bar	4 bar	VKV750~VKV1500 -10°C/+100°C VKV2000~VKV5000 -10°C/+70°C
Finitura esterna colore External finish color Couleur de finissage extérieur	Membrana in gomma Rubber membrane Vassie en caoutchouc	
Blu/Blue/Bleu RAL 5015	EPDM VKV750~1500 BUTYL VKV2000~5000	

Utilizzo - Use - Utilisation

Circuiti acqua calda, autoclave di pressurizzazione acqua calda
 Hot water circuits, pressurizing surge tanks
 Circuits eau chaude, réservoir de pressurisation eau chaude

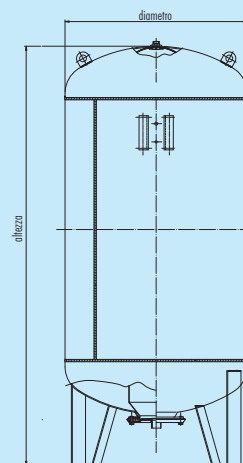

Codice Code Code	Modello Model Modèle	Altezza Height Hauteur (mm)	Diametro Diameter Diamètre (mm)	Imballo Packing Emballage (mm)	Attacco Connection Raccordement
AAXKG01R31GP1	VKV750	1770	800	(Pz1) 800X800X1920	2"
AAYKG01R31HP1	VKV1000	2250	800	(Pz1) 800X800X2400	2"
AAZKG01R31HP1	VKV1500	2400	960	(Pz1) 960X2400X1110	2"
AAAKG01R31NP1	VKV2000	2500	1100	(Pz1) 1100X2500X1250	2"
AABKG01R31OP1	VKV3000	2750	1200	(Pz1) 1200X2750X1350	Dn65
AA4KG02R31OP1	VKV4000	2950	1450	(Pz1) 1450X2950X1600	Dn80
AA5KG02R31OP1	VKV5000	3250	1500	(Pz1) 1500X3250X1650	Dn80

Autoclavi di altre capacità per la gamma 25/40 bar disponibili su richiesta
Tanks of different capacity and maximum working pressure 25/40 bar are available on request
Réservoirs de différentes capacités pour la gamme 25/40 bar sont disponibles sur requête



Autoclavi inox con membrana intercambiabile
Stainless steel tanks with interchangeable bladder
Réservoirs inox à vassie interchangeable

Marchi CE secondo la Direttiva PED 97/23/CE
CE marked according to Directive
Avec le marque CE selon la Directive

Pressione massima d'esercizio Maximum working pressure Pression maximale d'exercice	Pressione di precarica standard Standard pre-loading pressure Pression de precharge standard	Temperatura d'esercizio Working temperature Température d'exercice
10 bar (8bar 18-24)	1,5 bar 2 bar (AVX-AHX200)	-10°C/+100°C
Finitura esterna colore External finish color Couleur de finition externe	Membrana in gomma Rubber membrane Vassie en caoutchouc	
Inox/Stainless steel		EPDM

Utilizzo - Use - Utilisation

Circuiti acqua calda, autoclave di pressurizzazione acqua calda
Hot water circuits, pressurizing surge tanks
Circuits eau chaude, réservoir de pressurisation eau chaude

Codice Code Code	Modello Model Modèle	Altezza Height Hauteur (mm)	Lunghezza Length Longueur (mm)	Diametro Diameter Diamètre (mm)	Imballo Packing Emballage (mm)	Attacco Connection Raccordement
AAGXE00T01LA1	AX18	380	-	280	(Pz1) 280X280X430	1"
AAIXE00T01LA1	AX24	460	-	280	(Pz1) 280X280X495	1"
AAKXE01T01LA1	AVX50	700	-	370	(Pz1) 695X360X365	1"
AAMXE01T01LA1	AVX80	810	-	410	(Pz1) 814X404X408	1"
AANXE01T41LA1	AVX100	795	-	495	(Pz1) 806X501X502	1"
AAQXG01T41LA1	AVX200	1000	-	600	(Pz1) 1020X600X597	1"
AAGYE11T01LA1	AHX18	310	360	280	(Pz1) 306X286X482	1"
AAIYE11T01LA1	AHX24	310	470	280	(Pz1) 306X286X482	1"
AAKYE11T01LA1	AHX50	575	390	370	(Pz1) 565X365X384	1"
AAMYE11T01LA1	AHX80	460	640	420	(Pz1) 691X416X432	1"
AANYE11T41LA1	AHX100	530	680	500	(Pz1) 690X495X517	1"
AAQYG11T41LA1	AHX200	628	895	620	(Pz1) 915X600X615	1"

Autoclavi zincati con membrana intercambiabile
Galvanized pressure tanks with interchangeable bladder
Reservoirs zingué à vessie interchangeable

Marcati CE secondo la Direttiva PED 97/23/CE
CE marked according to Directive
Avec le marque CE selon la Directive

Pressione massima d'esercizio Maximun working pressure Pression maximale d'exercice	Pressione di precarica standard Standard pre-loading pressure Pression de precharge standard	Temperatura d'esercizio Working temperature Température d'exercice
10 bar	2 bar	-10°C/+100°C
Finitura esterna colore External finish coulor Couleur de finition externe	Membrana in gomma Rubber membrane Vassie en caoutchouc	
Zincato/Galvanized Zingué	EPDM	

Utilizzo - Use - Utilisation

Circuiti acqua calda, autoclave di pressurizzazione acqua calda
Hot water circuits, pressurizing surge tanks
Circuites eau chaude, réservoir de pressurisation eau chaude

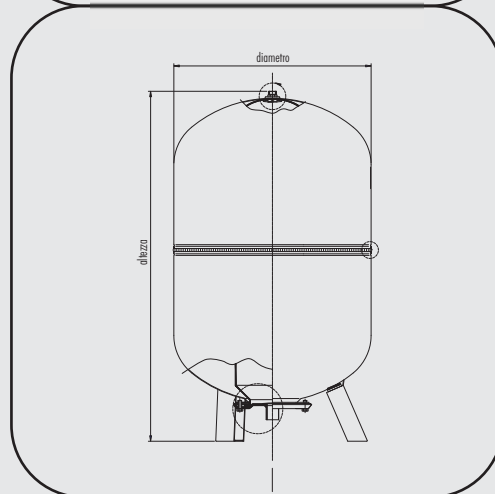

Codice Code Code	Modello Model Modèle	Altezza Height Hauteur (mm)	Diametro Diameter Diamètre (mm)	Imballo Packing Emballage (mm)	Attacco Connection Raccordement
AAKZG01T21EA1	AVZ50	700	365	(Pz1) 695X360X365	1"
AALZG01T21EA1	AVZ60	810	365	(Pz1) 809X369X358	1"
AAMZG01T21EA1	AVZ80	810	410	(Pz1) 814X404X408	1"
AANZG01T11EA1	AVZ100	795	495	(Pz1) 806X501X502	1"
AAPZG01T11EA1	AVZ150	933	550	(Pz1) 930X550X550	1"
AAQZG01T11FA1	AVZ200	1020	600	(Pz1) 1020X600X597	1 1/4"
AASZG01T11FA1	AVZ300	1153	650	(Pz1) 1270X650X650	1 1/4"
AAUZG01T11FA1	AVZ500	1470	750	(Pz1) 1487X732X745	1 1/4"

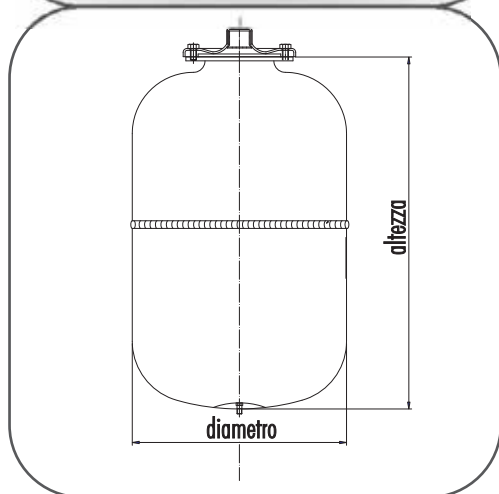

Vasi Multifunzione con membrana intercambiabile
Multifunction tanks with interchangeable bladder
Reservoirs multifonction à vassie interchangeable

Marchi CE secondo la Direttiva **PED 97/23/CE**
 CE marked according to Directive
 Avec le marque CE selon la Directive

Pressione massima d'esercizio Maximum working pressure Pression maximale d'exercicee	Pressione di precarica standard Standard pre-loading pressure Pression de precharge standard	Temperatura d'esercizio Working temperature Température d'exercice
10 bar (8bar 18-24)	1,5 bar	-10°C/+100°C

Finitura esterna colore
External finish coulor
Couleur de finition externe

Membrana in gomma
Rubber membrane
Vassie en caoutchouc

Bianco/White/Blanc
RAL 9010

EPDM

Utilizzo - Use - Utilisation

Circuiti acqua calda, autoclave di pressurizzazione acqua calda
 Hot water circuits, pressurizing surge tanks
 Circuits eau chaude, réservoir de pressurisation eau chaude

Codice Code Code	Modello Model Modèle	Altezza Height Hauteur (mm)	Diametro Diameter Diamètre (mm)	Imballo Packing Emballage (mm)	Attacco Connection Raccordement
AACME00W01BD1	AR2	265	110	(Pz8) 329X329X609	3/4"
AADME00W01BD1	AR5	296	160	(Pz8) 329X329X609	3/4"
AAEME00W01BD1	AR8	310	200	(Pz8) 419X419X638	3/4"
AAFME00W01BD1	AR12	295	280	(Pz8) 564X564X626	3/4"
AAGME00W01DC1	AR18	465	280	(Pz4) 551X551X430	3/4"
AAIME00W01EC1	AR24	492	280	(Pz4) 551X551X448	1"
AAJME00W01EA1	AR35	440	365	(Pz1) 451X366X382	1"

Modello Model Modèle	N° x scatola x box x boîte	Dimensioni pallet Dimension pallet Dimensions palette P x L x H _t	N° totale total total
VA2	12	1200x800x2000	216
VA5	8	1200x800x2000	144
VA8	8	1300x900x2100	144
VA12	8	1200x1200x2100	96
VA18	4	1200x1200x2200	64
VA24	4	1200x1200x2200	64
VA35	1	940x1200x2100	30
VAS24	2	800x1200x2300	36
VAV50	1	1200x1200x2050	20
VAV60	1	1200x1200x2000	20
VAV80	1	1250x1250x2300	20
VAV100	1	1350x1350x2200	16
VAV150	1	1200x950x1900	6
VAV200	1	1230x1030x1950	6
VAV300	1	1330x1280x2160	6
VAV500	1	1500x1500x2450	6

Modello Model Modèle	N° x scatola x box x boîte	Dimensioni pallet Dimension pallet Dimensions palette P x L x H _t	N° totale total total
VAV750	1	800x800x1920	1
VAV1000	1	800x800x2400	1
VAV1500	1	960x2400x1110	1
VAV2000	1	1100x2500x1250	1
VAV3000	1	1200x2750x1350	1
VAV4000	1	1450x2950x1600	1
VAV5000	1	1500x3250x1650	1
VA018	4	1200x1200x2200	64
VA024	4	1200x1200x2200	64
VA035	1	940x1200x2100	30
VA050	1	1200x1200x2100	30
VA060	1	1200x1200x2150	20
VA080	1	1200x1200x2400	20
VA0100	1	1200x1200x225	16
VA0150	1	1200x840x2000	6
VA0200	1	1230x930x2050	6
VA0300	1	1380x1280x2160	6

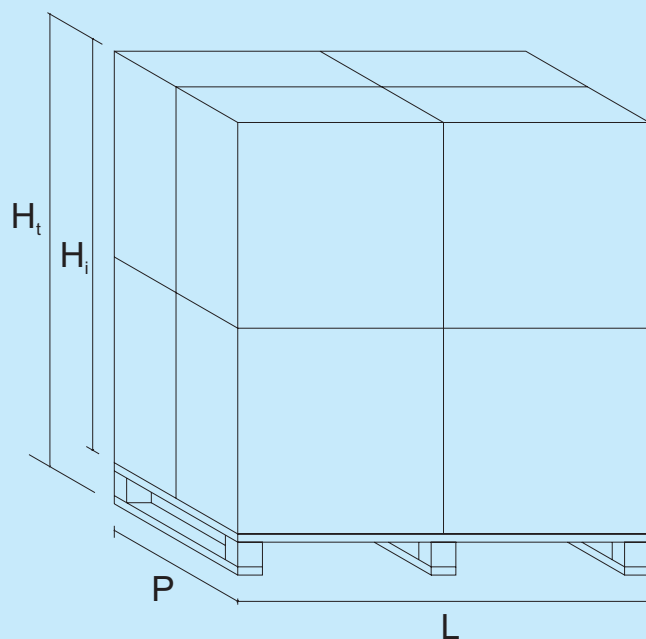

accessori e ricambi
accessories and spare parts
accessoires
et pièces de rechange



Membrane intercambiabili

Interchangeable bladders - Vassies interchangeable

Codice Code Code	Modello Model Modèle	∅ mm	Utilizzabile per i modelli Usable for models Utilisable pour modèles	Con foro per tirante With hole for tie beam avec trou pour entrain
ME012A	EPDM	45	VA2 VA5 VA8 VA12 AR2 AR5 AR8 AR12	
ME024A	EPDM	80	VAO18 VA24 VAO24 VAS24 AR18 AR24	
ME050A	EPDM	80	VA35 VAO35 VAV50 VAO50 AR35	
ME080A	EPDM	80	VAV60 VAO60 VAV80 VAV80	
ME100A	EPDM	80	VAV100 VAO100	X
ME150A	EPDM	80	VAV150 VAO150	X
ME200A	EPDM	200	VAV200 VAO200	X
ME300A	EPDM	200	VAV300 VAO300	X
ME500A	EPDM	200	VAV500	X
MEN10A	EPDM	200	VAV750 VAV1000	X
MEN20A	EPDM	220	VAV1500 VAV2000	X
MEN30A	EPDM	250	VAV3000	X

ME012R	EPDM	45	VR2 VR5 VR8 VR12 VS12	
ME024R	EPDM	80	VR18 VR24 VS18 VS24	
ME050R	EPDM	80	VR35 VRV35 VR50 VRV50 VS35 VSV50	
ME080R	EPDM	80	VRV80 VRV80 VSV80	
ME150R	EPDM	80	VRV100 VRV120 VRV150	
ME300R	EPDM	80	VRV200 VRV250 VRV300	X
ME500R	EPDM	200	VRV400 VRV500	X
ME600R	EPDM	200	VRV600	X
MEN10R	EPDM	200	VRV750 VRV1000	X
MEN20R	EPDM	220	VRV1500 VRV2000	X
MEN30R	EPDM	250	VRV3000	X

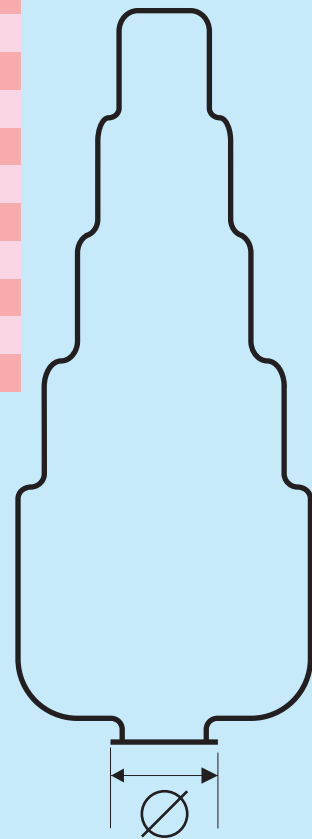
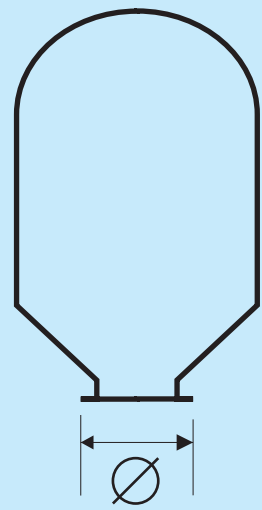

Staffa per fissaggio a muro - Wall bracket - Support pour fixation murale

Codice	raccordo da
Code	connection
Code	raccordement
SUP001	3/4"
SUP002	1"



Controflangia - Counter flange - Contre-bride

Codice Code Code	∅ mm	Attacco Connection Raccordement	Finitura Finish Finissage
CFF095TRF008Z	95	3/4"	Zincato/Galvanized/Zingué
CFF095TRF007Z	95	1"	Zincato/Galvanized/Zingué
CFX095TRX004B	95	1"	Inox/Inox/Inox
CFF145TRF008Z	145	3/4"	Zincato/Galvanized/Zingué
CFX145TRX008B	145	3/4"	Inox/Inox/Inox
CFF145TRF007Z	145	1"	Zincato/Galvanized/Zingué
CFX145TRX004B	145	1"	Inox/Inox/Inox
CFF260TRF001Z	260	1 1/4"	Zincato/Galvanized/Zingué
CFX260TRX001B	260	1 1/4"	Inox/Inox/Inox



Interruttore galleggiante - Float switch - Interrupteur à flotteur

Codice	Cavo
Code	Cable
Code	Câble
IGLCN005	0,5 m
IGLCN050	5 m
IGLCN100	10 m



Pressostato -Pressostat - Pressostat

Codice	bar	Modello
Code		Model
Code		Modèle
PM5	1 ÷ 5	PRITCPM5
PM12	3 ÷ 12	PRITCPM12



Flessibile MF - Flexible piping - Tube flexible

Codice Code Code	L (mm)	Attacco Connection Raccordement
FMFG0150	500	1"
FMFG0160	600	1"
FMFG0180	800	1"
FMFG01N1	1000	1"



Manometro - Manometer - Manometre

Codice Code Code	∅ mm	Modello Model Modèle	Pressione Pressure Pression
MANAR5206	50	Radiale	0 ÷ 6
MANAR5212	50	Radiale	0 ÷ 12
MANAP5206	50	Assiale	0 ÷ 6
MANAP5212	50	Assiale	0 ÷ 12



Raccordo - Water connection - Raccordement au chauffe-eau

Codice Code Code	∅ (inch)	Modello Model Modèle	L (mm)
RAC3V172	1"	3 vie	72
RAC5V172	1"	5 vie	71,5
RAC5V182	1"	5 vie	82
RAC5V192	1"	5 vie	91



Tirante per fissaggio a membrana - Tie rod - Entrait

Codice Code Code	∅ (mm)	Modello Model Modèle
TIR001Z	60	100~500
TIR003Z	90	750~5000

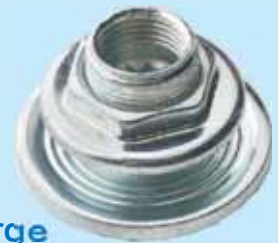

Valvola di precarica - Precharge valve - Valve de précharge

Codice / Code / Code VAL003

L'acquirente si impegna a controllare i prodotti e l'imballaggio non appena effettuata la consegna.

Qualora venga accertato un difetto di fabbricazione e questo venga notificato nei termini della legge italiana (8 giorni dalla scoperta degli stessi), l'acquirente dovrà provvedere ad inviare i pezzi difettosi alla sede di Aquasystem, in porto franco, perché la stessa provveda alla sostituzione dei materiali difettosi.

L'acquirente ottenuta la sostituzione, non avrà diritto ad alcun indennizzo, sconto o ulteriore risarcimento oltre a tale sostituzione.

Nel caso in cui la Aquasystem non venga informata in merito ad eventuali difetti originari dei prodotti entro 8 giorni dalla data riportata sul documento di consegna, si presumerà che i prodotti medesimi non abbiano vizi/difetti e, pertanto, la Aquasystem non accetterà reclami relativamente agli stessi.

Aquasystem infatti non si assume responsabilità per gli articoli danneggiati successivamente alla consegna.

Tutti i prodotti Aquasystem hanno una garanzia di 24 mesi a partire dalla data di recapito.

Farà fede in questo senso la data sui documenti di consegna.

Tale garanzia è condizionata ad una corretta installazione del prodotto, in accordo con gli standard italiani ed europei ed inoltre, con le istruzioni riportate in questo manuale.

Le parti concordano espressamente che la garanzia venga meno in caso di interventi da parte di terzi relativamente a prodotti difettosi.

La Aquasystem, infatti, non si assume responsabilità per le sostituzioni e/o riparazioni effettuate da terzi sui propri prodotti.

In ogni caso, la garanzia è limitata alla mera sostituzione o riparazione gratuita del prodotto, con l'esclusione di ogni altro diritto di qualsivoglia indennizzo, sconto o ulteriore risarcimento.

Non sono ammessi reclami di nessun tipo in ordine all'attività di riparazione/sostituzione dei prodotti difettosi.

Ogni prodotto restituito in garanzia resterà di esclusiva proprietà della Aquasystem.

Ogni controversia che dovesse sorgere riguardo i punti precedentemente enunciati, si riterrà unico Foro giudiziario competente quello di Bassano del Grappa ed unica legge applicabile sarà quella italiana.

Tutte le immagini e i disegni tecnici presenti in questo manuale sono puramente indicative.

Aquasystem si riserva la facoltà di apporre modifiche di qualunque tipo senza alcun tipo di preavviso, che a suo insindacabile giudizio comportino miglioramenti del prodotto stesso.

The buyer undertakes to inspect and verify every supplied product and the packaging immediately upon receipt.

According to the Italian law, should the product be defective in original components, the buyer must notify the seller of any defects within 8 days from the date that the defect was discovered.

In this event, the buyer must return free port the faulty item back to us so that Aquasystem will replace it.

Once the replacement is made, the buyer has not right to any further indemnity, discount or refund.

If Aquasystem is not informed within this time upon receipt, we will assume that the goods have been delivered in perfect conditions.

Therefore, Aquasystem will not accept any claim which has not been notified within the above mentioned time limits allowed.

Aquasystem, in fact, is not responsible for goods damaged after delivery.

All Aquasystem products have 24 months warranty from delivery date .

This warranty is only valid if the product is correctly installed according to Italian and European standards and to the instructions contained in this handbook.

The parties expressly agree that the warranty expires when third parties modify the delivered goods by any means.

Aquasystem, in fact, is not responsible for substitutions/repairs made by third parties on its products.

At all events, the guarantee only covers the free replacement or repair of the defective product. Any further indemnity, discount or refund is excluded.

The buyer is not entitled to advance any claim against the seller relating to the repair/substitution of the defective product.

Any product replaced under this warranty remains of exclusive property of Aquasystem.

Should any dispute or controversy arise, the place of jurisdiction shall be Bassano del Grappa and the Italian law the only one that will be applied.

All the illustrations and the technical drawings in this catalogue are just as an indication.

They are subject to change without notice at any time at Aquasystem's sole discretion.

On recommande à l'acheteur de vérifier les produits et l'emballage au moment de la livraison.

Dans le cas où il y a un défaut de fabrication, il faut le notifier dans un délai de 8 jours dès leur découverte aux termes de la loi italienne.

L'acheteur devra renvoyer franco de port au vendeur les pièces défectueuses aux fins de remplacement.

Après avoir obtenu le remplacement, aucune indemnité, réduction ou remboursement n'est allouée.

Au cas où Aquasystem ne soit pas informé des fautes de fabrication dans un délai de 8 jours à partir du moment de la livraison, la marchandise sera réputée définitivement agréée par le client.

Pour cette raison, aucune réclamation ne sera admise plus de 8 jours après la livraison. Aquasystem au fait n'est pas responsable des dommages survenu après la réception.

Tous les produits Aquasystem ont 24 mois de garantie.

La date sur les documents d'expédition fera foi.

La validité de notre garantie reste subordonnée à une correcte installation du produit, selon les standards italiens et européens. et selon les instructions décrites dans le présent manuel.

Les parties concordent que la garantie ne peut être invoquée si des tiers interviennent sur les produits défectueux.

Aquasystem au fait ne s'assume pas la responsabilité pour les substitutions/réparations effectués par tiers sur les produits.

En tout cas, la garantie se limite exclusivement au remplacement ou à la réparation du produit défectueux. Aucune autre indemnité, réduction ou remboursement n'est allouée.

Aucune réclamation ne sera acceptée qui concerne la substitution/réparation des produits défectueux.

Toutes les pièces défectueuses qui ont été remplacées en cas d'une faute de fabrication sous les termes de la garantie restent d'exclusive propriété de Aquasystem.

Pour toutes les controverses dérivant de l'interprétation et exécution de cette garantie, le seul Tribunal compétent est celui de Bassano del Grappa et la seule loi applicable sera la loi italienne.

Tous les images et les dessins techniques sont présentées à titre indicatif seulement.

Ils sont sujets à changements sans préavis pour part de Aquasystem.

Aquasystem srl



AQUASYSTEM®

Aquasystem srl

via Camazzole, 50/A
35010 Carmignano di Brenta (PD)
Tel +39 049 5957221 - Fax +39 049 9431153
www.aquasystem.it - info@aquasystem.it